

AND

BLOCKWIRING AGREEMENT

BLOCKWIRING AGREEMENT

THIS AGREEMENT is made on

BETWEEN:

and

AND:

RECITAL

- A. The Parties have agreed the terms and conditions on which each Party shall provision and permit the other party to use its Blockwiring.
- B. This Agreement sets out the terms and conditions on which each Party shall provision transmission capacity over its Blockwiring to the other Party.

OPERATIVE PROVISIONS

1. DEFINITIONS AND INTERPRETATION

- 1.1 The following terms used in this Agreement shall have the following meaning, unless a contrary intention is specified:

“Agreement” means these terms and conditions and the attached Schedules as amended from time to time in accordance with clause 19.9.

Applicable Law means any law, rule or regulation of Hong Kong or any country (or political sub-division thereof) which is applicable to either Party, the use of Blockwiring or the provision of service by any Party to a Subscriber; obligations under any telecommunications or other licence held by any Party or any person to whom a Party provides services; any lawful determination, decision or direction of the TA or a Government Agency in Hong Kong or any country (or political subdivision thereof) which is applicable to a Party or the use of the Blockwiring; and any applicable international convention or agreement.

“Associate Company” in relation to a Party means:

- (a) a “subsidiary” of that Party, a “holding company” of that Party and a “subsidiary” of the same “holding company” as those terms are defined in the Companies Ordinance (Cap 32) of Hong Kong; and

- (b) any corporate partnership in which one or more companies referred to in paragraph (a) together hold a controlling interest.

"Available Date" means the day when the Owner informs the Requesting Operator that leased transmission capacity over the Blockwiring specified in an accepted Order is available to the Requesting Operator and that that Blockwiring can be operated in accordance with the specifications set out in Schedule 2.

"BIP" means a physical interfacing device and associated cabling for connecting the BIP with the termination point of the Owner's main distribution frame specifications of which are set out in Schedule 1, or such other device which may be agreed between the Parties from time to time, which is installed as close as practically possible to the Owner's main distribution frame (usually located on the ground floor or in the basement of the relevant Blockwiring Building) for connecting the Requesting Operator's Network to the Blockwiring to be provisioned in accordance with this Agreement.

"BIP Application" means a written application by the Requesting Operator to the Owner in accordance with Schedule 1 in relation to the provisioning of a BIP.

"BIP Charge" means the charge payable under this Agreement in accordance with clause 9.1 and Schedule 3.

"BIP Specifications" means the specifications for a BIP as set out in Schedule 1.

"Blockwiring" means any two wire copper blockwiring circuit owned by the Owner in place within a Blockwiring Building which may consist of either Vertical Blockwiring or a combination of Vertical Blockwiring and Horizontal Blockwiring.

"Blockwiring Building" means any building, building estate or multi-tower building complex in which there is Blockwiring and in respect of which the Parties have made arrangements for the provision of a BIP in accordance with this Blockwiring Agreement.

"Blockwiring Charges" means the charges payable under this Agreement in accordance with clause 9 and Schedule 3.

"Business Day" means a day other than a Saturday or Sunday or a public holiday in Hong Kong.

"Contract" means each individual agreement for the provisioning of leased transmission capacity over Blockwiring which is established in accordance with clause 3.1.

"Force Majeure" means anything outside reasonable control of the Party including (insofar as it is outside the reasonable control of that Party) acts of God, industrial disputes of any kind, war declared or undeclared, blockade, disturbance, lightning, fire, earthquake, storm, flood, explosion or meteor, governmental restraint, expropriation or prohibition, any action or event that infringes property rights, inability or delay in granting or obtaining governmental approvals, consents, permits, licences or authorities including but not limited to, from Government Agencies, or termination or withdrawal of such approvals, consents, permits or licences.

"FTNS Licence" means the Fixed Telecommunications Network Services licence granted to each Party pursuant to the *Telecommunication Ordinance*, as amended from time to time.

"Government" means the Government of the Hong Kong Special Administrative Region.

"Government Agency" means any government or government department, a

governmental, semi-governmental or judicial person or a person (whether autonomous or not) charged with the administration of any Applicable Law (including but not limited to the Telecommunications Authority).

"**Hong Kong**" means the Hong Kong Special Administrative Region of the People's Republic of China.

"**Horizontal Blockwiring**" means that section of a two wire copper blockwiring circuit in place within a Blockwiring Building connecting a Local Box and a Termination Socket or a terminating frame.

"**Local Box**" means the apparatus located on a floor of a Blockwiring Building which the Owner uses to terminate the Vertical Blockwiring on that floor.

"**Loss**" includes loss, cost, damage, expense and charge.

"**Minimum Contract Period**" means the minimum period of each Contract as specified in clause 3.2 commencing on the applicable Available Date, for which the Requesting Operator shall pay monthly recurrent charges to the Owner in accordance with this Agreement.

"**Network**" of a Party means the fixed telecommunications network of that Party operated, established and maintained by that Party in accordance with its FTNS Licence.

"**O&M Manual**" means the operations and maintenance manual, a draft of which is set out in Attachment A, as updated from time to time in accordance with this Agreement and the procedures set out in the O&M Manual.

"**Order**" means a written order from the Requesting Operator to the Owner which contains information specified in clause 2, Part B of Schedule 2 for the provision of leased transmission capacity over Blockwiring in accordance with this Agreement.

"**Owner**" means the Party which provisions leased transmission capacity over Blockwiring to the Requesting Operator in accordance with this Agreement.

"**Party**" means _____ or _____, and "**Parties**" means both of them.

"**Requesting Operator**" means the Party which requests the Owner to provision leased transmission capacity over Blockwiring in accordance with this Agreement.

"**Standard Provisioning Period**" means the standard target provisioning period that is specified in clause 6.1, Part C of Schedule 2 for the provisioning of leased transmission capacity over Blockwiring after an Order has been accepted by the Owner.

"**Subscriber**" means the person to whom a Party supplies telecommunication services over Blockwiring.

"**Tax**" means any present or future tax, levy, impost, deduction, charge, duty, compulsory loan or withholding tax (together with any related interest, penalty, fine and expense in connecting with any of them) levied or imposed by any Government Agency, other than those imposed on overall income.

"**Telecommunications Authority**" or "**TA**" has the meaning given to the term "**Authority**" in the Telecommunications Ordinance.

"**Termination Socket**" means the standard socket pre-provisioned (before the Order) by the Owner at a Subscriber's premises for terminating the Owner's Horizontal

Blockwiring in order to provide service to that Subscriber's premises.

"Vertical Blockwiring" means that section of a two wire copper blockwiring circuit in place within a Blockwiring Building connecting the BIP or the termination point of a tie-cable connecting to the BIP, and a Local Box, and where only Vertical Blockwiring is being provisioned, Vertical Blockwiring includes any jumper or a connector referred to in clause 9.2, Part D of Schedule 2.

- 1.2 The Parties shall use their respective reasonable endeavors to finalise the draft O&M Manual within 3 months of the date of execution of this Agreement.

2. ORDERING AND ACCEPTANCE PROCEDURES

- 2.1 From time to time, the Requesting Operator may place an Order.

- 2.2 The Owner may reject an Order only:

- (a) in accordance with clause 4.1, Part B of Schedule 2; or
- (b) if the Blockwiring required to fulfill the Order is not available on the date of receipt of the Order.

- 2.3 For the purpose of clause 2.2(b) of this Agreement and clause 3.1 of Schedule 2 and subject to clauses 2.6, 2.7 and 2.8 of this Agreement, Blockwiring shall be regarded as being available if all the conditions set out in following paragraphs are satisfied:

- (a) there is suitable Vertical Blockwiring in place in the Blockwiring Building proposed in the Order which complies with the relevant specifications set out in Schedule 2;
- (b) in the case of an Order for Vertical Blockwiring combined with Horizontal Blockwiring, there is Horizontal Blockwiring and a Termination Socket in place or the Requesting Operator provides its own horizontal block wiring or the Parties agree the terms and conditions on which the Owner shall install that horizontal block wiring; and
- (c) the Blockwiring is not on the date of receipt of the Order:
 - (i) subject to clauses 2.4 and 2.5 below, being used by any person (including the Owner); or
 - (ii) reasonably required to be used by the Owner during the period of 24 months after the proposed Available Date on the basis of the Owner's current business plan at the date of receipt of the applicable Order; or
 - (iii) the subject of an order received by the Owner from a third party (including another telecommunication service provider) on or before the date of receipt of the Order by the Owner; or
 - (iv) the subject of a bona fide order placed with the Owner on or before the date of receipt of the Order by a person (other than a telecommunication service provider) who wishes to use the Blockwiring or a service provided by the Owner using the Blockwiring (other than Blockwiring referred to in clause 2.4 below); or

- (v) subject to any of the circumstances described in clause 3.4 of this Agreement which, if the Blockwiring were provisioned, the Owner would be entitled to terminate the Contract under that clause.

2.4 If the Owner is providing telecommunication services to a Subscriber over any Blockwiring and that Subscriber wishes to terminate all services provided over that Blockwiring and become a Subscriber of the Requesting Operator and that Blockwiring is suitable for re-use and of a kind referred to in clauses 2.3(a) and 2.3(b) and clauses 2.6 and 2.7 of this Agreement, then that Blockwiring is available for the purpose of clause 2.2(b) of this Agreement if:

- (a) the Owner's standard disconnection notice has been signed by a duly authorised representative of that Subscriber;
- (b) the original of the signed disconnection notice referred to in paragraph (a) has been provided to the Owner's customer front office and a copy of that signed disconnection notice together with the applicable Order has been provided to the Owner in accordance with clause 17 of this Agreement;
- (c) the Owner has received a written confirmation issued by the Requesting Operator confirming that that Subscriber wishes to apply for any telecommunication service from the Requesting Operator; and
- (d) the disconnection notice has not been revoked or cancelled (in whole or in part) by that Subscriber before the relevant Blockwiring is provisioned.

2.5 If the Requesting Operator orders Blockwiring that on the date of receipt of the Order is used by any third party (including a telecommunication service provider) to serve a person who wishes to become a Subscriber, the Requesting Operator, must agree further arrangements with that other party and the Owner.

2.6 Acceptance of an Order shall be conditional on suitable arrangements being made for the provision of BIP for the relevant building in accordance with clause 5 below.

2.7 The Owner's obligation to provision leased transmission capacity over either Vertical Blockwiring or Vertical Blockwiring combined with Horizontal Blockwiring is limited to existing copper wiring on the date of receipt of the Order and a Termination Socket which comply with the relevant specifications set out in Schedule 2. The Owner is under no obligation to install any new blockwiring or sockets as a result of this Agreement.

2.8 Subject to clause 18 below, this Agreement applies to all Blockwiring provisioned during the term of this Agreement.

3. CONTRACT

3.1 If the Owner informs the Requesting Operator that its Order has been accepted under Schedule 2, a Contract shall be deemed to have been established between the Owner and the Requesting Operator in respect of the specified Blockwiring. Clauses 3 to 19 (inclusive) of this Agreement are deemed to be incorporated in each Contract as its terms and conditions.

3.2 The Minimum Contract Period for each Contract is 12 months subject to the right of a Party to terminate in accordance with this clause 3 and clause 10 below.

- 3.3 Without prejudice to clause 10, the Requesting Operator may terminate a Contract by giving 1 month written notice to the Owner at any time after expiration of 12 months calculated from the Available Date of the subject Blockwiring.
- 3.4 Without prejudice to clause 10, the Owner may terminate a Contract:
- (a) by giving 6 months notice to the Requesting Operator if:
 - (i) a notice of demolition of the Blockwiring Building has been issued (except that if the Owner is given less than 6 months notice of demolition of a Blockwiring Building from the owner of that building, the Owner must notify the Requesting Operator as soon as practicable after receiving notice from the owner of the Blockwiring Building of its demolition); or
 - (ii) the Owner or third party conducts a technology upgrade to the subject Blockwiring, but direct replacement of an existing wire by a standard Cat 3 copper wire shall not be a ground for which the Owner may terminate a Contract under this clause. In the event of such a technology upgrade, the Parties may negotiate in good faith for appropriate terms and conditions in relation to the provisioning of leased transmission capacity over the subject Blockwiring
 - (iii) the Owner assigns ownership of the subject Blockwiring. In the event of a proposed assignment of ownership by the Owner of the relevant Blockwiring to an Associate Company, the Owner shall endeavour to procure the assignee to continue provisioning leased transmission capacity over that affected Blockwiring until expiration of the term of the Minimum Contract Period; or
 - (iv) the Owner loses Universal Service Obligation in a particular geographical area where that Blockwiring Building is located; or
 - (b) by giving to the Requesting Operator as much prior notice as is reasonably practicable, if the Owner no longer retains ownership or the use of the subject Blockwiring by force of the Applicable Law or lawful exercise of a right (but not including an assignment referred to in sub-paragraph (a)(iii) above); or
 - (c) by giving 5 days notice to the Requesting Operator, if the Subscriber to which the Requesting Operator provides telecommunication services over a Blockwiring has applied to the Owner to become a Subscriber of the Owner for services provided by the Owner and:
 - (i) the Requesting Operator's standard disconnection notice has been duly signed by a duly authorised representative of that Subscriber;
 - (ii) the original of the signed disconnection notice referred to in sub-paragraph (i) has been provided to the Requesting Operator's customer front office and a copy of that signed disconnection notice together with the applicable Order has been provided to the Requesting Operator in accordance with clause 17;
 - (iii) the Requesting Operator has received a written confirmation issued by the Owner confirming that the Subscriber wishes to apply for any telecommunication service from the Owner; and
 - (iv) the disconnection notice referred to in paragraph (i) has not been

revoked or cancelled (in whole or in part) by that Subscriber before the Owner gives notice of termination to the Requesting Operator.

- 3.5 The Owner may give notice to the Requesting Operator at any time during the term of a Contract if the Owner requires to use the Blockwiring the subject of that Contract, and if as at the date of that notice or after the date of receipt of that notice:
- (a) the Requesting Operator or one of its Associate Companies owns or has access to blockwiring or other transmission capacity in that building that is reasonably substitutable for the Blockwiring and is not being used to supply a telecommunication service to a Subscriber in the Blockwiring Building; or
 - (b) the Requesting Operator has a right to be provided with reasonably comparative rights of use from a third person in respect of blockwiring or other transmission capacity that is reasonably substitutable for that Blockwiring and has not been lawfully refused; or
 - (c) the Subscriber of the Requesting Operator in that Blockwiring Building has terminated all telecommunication services provided over that Blockwiring by the Requesting Operator; or
 - (d) the Requesting Operator does not have a Subscriber in that Blockwiring Building for telecommunication services provided over that Blockwiring (but this paragraph (d) does not apply during the initial period of 6 months after the Available Date of that Blockwiring),

then that Blockwiring shall no longer be available for use by the Requesting Operator under this Agreement and the Requesting Operator must notify the Owner within 5 Business Days of the existence of any or all of the circumstances in paragraphs (a) to (d) and disconnect that Blockwiring from its Network as soon as is reasonably possible. If there is any bona fide dispute in relation to whether paragraph (a), (b), (c) or (d) of this clause applies or in relation to the relevant technical implementation, the Parties shall resolve that dispute in accordance with the dispute resolution procedures in clause 16. For the avoidance of doubt, the Requesting Operator shall not be required to pay the Blockwiring Recurrent Charge for the full term of the Minimum Contract Period under Clause 9.2 if the Owner requires to use the Blockwiring of a Contract pursuant to any of the circumstances specified in Clause 3.5(a) to (d).

4. PROVISIONING

- 4.1 Where Blockwiring is available under this Agreement, the normal target lead-time for making leased transmission capacity over that Blockwiring available to the Requesting Operator is the Standard Provisioning Period in accordance with Schedule 2.
- 4.2 The Parties shall provision Blockwiring under this Agreement in accordance with Schedule 2 and the O&M Manual.
- 4.3 The Requesting Operator acknowledges that the Owner gives no warranties or representations in relation to the Blockwiring other than warranting that the Blockwiring shall comply with the specifications set out in Schedule 2 so long as and to the extent it is not being applied to a use which is outside those specifications.
- 4.4 Nothing in this Agreement is to be construed as vesting in the Requesting Operator any right of use in respect of any Blockwiring the grant or enjoyment of which would contravene the Applicable Law, or breach any licence, permit or approval issued by any Government Agency, or infringe any right of or breach any arrangement with a third

person (including the building owner or a third party with property interest).

5. ARRANGEMENTS FOR BIP

- 5.1 The Requesting Operator may, from time to time, send a BIP Application to the Owner for the provision of a BIP in accordance with either clause 5.1(a) or clause 5.1(b) of Schedule 1.
- 5.2 The Requesting Operator shall provide the BIP, save for and except where the circumstances set out in clause 5.3 below prevail, and the Requesting Operator:
- (a) must ensure that the BIP is installed as close as practical to the Owner's main distribution frame and is responsible for (and for all costs incurred in) providing any additional trunking and other cabling facilities required in relation to the installation of the BIP;
 - (b) shall be responsible for maintaining the BIP and to provide additional capacity to the BIP if its order for leased transmission capacity over Blockwiring exceeds the prevailing capacity of the BIP; and
 - (c) shall be responsible for the provisioning and maintaining tie cables connecting the BIP with the termination point of Owner's main distribution frame if the BIP and the Owner's main distribution frame are located in different rooms, or if the tie cable distance is more than 10 meters.
- 5.3 The Requesting Operator may elect to request that the BIP be provisioned by the Owner in accordance with clause 5.1(b) of Schedule 1 where it is impractical for the Requesting Operator to provision the BIP itself. In such a case, the Requesting Operator must pay the BIP Charge and the Owner shall provision the BIP in accordance with this Agreement. The Owner shall maintain the BIP in accordance with this Agreement and the O & M Manual for the term of this Agreement
- 5.4 Each Party must ensure that each BIP provisioned by it complies with the BIP Specifications. The Owner may vary the BIP Specifications in accordance with Schedule 1 and notify the Requesting Operator in writing. Each BIP provisioned after the variation date must comply with the new specifications, but each BIP that has already been installed shall not be affected by the variation.
- 5.5 Further details in relation to each BIP provisioned by the Requesting Operator including identification, site location and physical arrangements shall be resolved by the Owner and the Requesting Operator acting in good faith on a case by case basis according to the actual site situation.
- 5.6 Irrespective of whether the BIP is provisioned by the Owner or the Requesting Operator:
- (a) the Requesting Operator shall be responsible for providing facilities for its equipment, distribution frame, external cables, tie cables, and jumpering to connect its Network to the BIP; and
 - (b) the BIP shall serve as a demarcation point between the Blockwiring and the remainder of the Requesting Operator's Network.

6. LOCAL BOX

- 6.1 This clause 6 applies where leased transmission capacity is provisioned by the Owner over Vertical Blockwiring only.
- 6.2 The Vertical Blockwiring shall be terminated on each floor at the corresponding Local Box or in such other manner as may be described in the O&M Manual. The Owner is responsible for maintaining the Vertical Blockwiring up to and inclusive of the Local Box for the term of the Contract.
- 6.3 The Requesting Operator is responsible for providing a separate local sub-box, tie-cables and other facilities necessary for connecting its local sub-box and horizontal wiring to the Local Box. If the Requesting Operator specifies in the Order that it shall not be providing a local sub-box, then a B-wire connector shall be installed by the Owner in accordance with the O&M Manual.

7. TERMINATION SOCKET

- 7.1 Where leased transmission capacity is provisioned over Vertical Blockwiring combined with Horizontal Blockwiring then:
- (a) the Owner is responsible for maintaining the Blockwiring up to and including the Termination Socket for the term of the Contract but shall not be responsible for maintaining the Termination Socket in the instances referred to in clauses 7.2 or 8.5(d); and
 - (b) the Owner is not responsible for relocating the Termination Socket or providing any wiring beyond the Termination Socket at the Subscriber's premises;

unless otherwise agreed by the Owner at the time of termination of a Contract, the Requesting Operator must reinstate the Termination Socket to the condition it was provisioned on the Available Date as soon as the relevant Contract is terminated or at least 30 days before the termination of the relevant Contract the Requesting Operator may request in writing that the Owner reinstates the Termination Socket at a charge to be agreed between the Parties and paid to the Owner by the Requesting Operator.

- 7.2 If the Requesting Operator intends to replace any Termination Socket, it must comply with the procedures set out in the O&M Manual and must reinstate the Termination Socket to the condition it was provisioned on the Available Date as soon as the relevant Contract is terminated unless otherwise agreed by the Owner at the time of such termination.

8. FAULT REPORTING, MAINTENANCE AND RELOCATION

- 8.1 The Requesting Operator acknowledges that the Owner is under no obligation to receive fault reports from Subscribers or other persons or to conduct any fault detection and rectification except as expressly required by this Agreement to maintain Blockwiring in accordance with the specifications set out in Schedule 2 and the O&M Manual following notification of a fault by the Requesting Operator and, accordingly, the Requesting Operator must:
- (a) receive any fault reports in respect of Blockwiring made by the Subscriber or any

other person;

- (b) ascertain that the fault reported by the Subscriber is not the result of any equipment or facility other than the Blockwiring;
 - (c) having properly determined that the fault appears to have occurred in the Blockwiring, provide the Owner with a fault report describing the fault symptoms; and
 - (d) otherwise comply with fault notification procedures that the Parties may agree from time to time.
- 8.2 Upon receiving the necessary information from the Requesting Operator in relation to faulty Blockwiring, the Owner shall use its reasonable efforts to repair and restore service of the faulty Blockwiring within the target restoration period specified in and subject to the terms of Schedule 2.
- 8.3 The Owner may choose to replace any Blockwiring under a Contract, either for operational reasons or other reasons beyond the control of the Owner. The Owner must use its reasonable endeavors to minimise any service interruption to Subscribers of the Requesting Operator because of such replacement and must:
- (a) in the case of replacement of all of the Blockwiring in a Blockwiring Building for preventive maintenance purposes - give the Requesting Operator at least 7 Business Days prior notice of the replacement; or
 - (b) in the case of other replacements - give the Requesting Operator substantially the same period of notice which the Owner would give its customers in similar circumstances notice of such replacement,
- except where such notice is not practical due to emergency.
- 8.4 If the Requesting Operator notifies the Owner of a number of faults in a Blockwiring over a reasonably short period of time but that Blockwiring still operates in accordance with the specifications set out in Schedule 2, the Parties shall negotiate in good faith (including any increase in the Charges) in relation to any other technical or commercial alternatives in response to the fault.
- 8.5 The Requesting Operator must not access, handle, or conduct any work on the Local Box or the Blockwiring, except with the express consent and in the presence of the Owner's authorised representative. While performing maintenance work, the Requesting Operator must not interfere with the wiring circuits and other facilities of the Owner, except:
- (a) the demarcation point at the BIP;
 - (b) the demarcation point at Requesting Operator' sub local box;
 - (c) the B-Wire connector end of the Horizontal Blockwiring provided by the Requesting Operator; and
 - (d) the Termination Socket but subject to clause 7.
- 8.6 The Requesting Operator must:
- (a) use its reasonable efforts to provide the Owner with safe and reasonable access to the relevant Subscriber's premises as may be reasonably required to enable the Owner to perform its obligations under this Agreement;

- (b) obtain the permission of any third person required to give effect to paragraph (a); and
 - (c) not authorise or allow any person other than a person reasonably identified as an authorised representative of the Owner to maintain, modify, repair or interfere with the Blockwiring, the Local Box and the Owner's BIP.
- 8.7 The Requesting Operator acknowledges and agrees that where the Owner's obligations under this Agreement are contingent on it obtaining access and safe and reasonable access to a Subscriber's premises then the Owner is relieved of its obligations under this Agreement to the extent that the Requesting Operator is unable to ensure access by the Owner under the conditions described in clause 8.6(a) above.

9. CHARGES AND PAYMENT

- 9.1 The Requesting Operator must pay the Blockwiring Charges specified in Schedule 3 as follows:
- (a) the BIP Charge is payable upon completion of the installation of a BIP provided by the Owner under clause 5.3 above, and if the Owner has already installed a BIP in the relevant building the BIP Charge shall be payable when the Requesting Operator places the first Order in respect of that building;
 - (b) the Blockwiring One-off Charges are payable on the actual Available Date of the specified Blockwiring;
 - (c) the Blockwiring Recurrent Charge is payable each month in advance, and the first payment of such charge in respect of a Blockwiring shall be calculated from the actual Available Date for that Blockwiring; and
 - (d) any other charges specified in Schedules 1, 2 and 3 are payable in accordance with Schedule 3.
- 9.2 The Requesting Operator must pay the Blockwiring Recurrent Charge for the full term of the Minimum Contract Period in respect of each Contract irrespective of whether it actually utilises that Blockwiring during that period, unless:
- (a) the Owner is able immediately to provision that Blockwiring to another telecommunication service provider on substantially similar terms and conditions as the applicable Contract for the balance of the Minimum Contract Period; or
 - (b) the Owner requires the Blockwiring immediately to provide telecommunications services for the balance of the Minimum Contract Period.
- 9.3 The Parties must comply with the billing and settlement procedures set out in Schedule 3.
- 9.4 All Blockwiring Charges are subject to increase and CPI adjustment in accordance with Schedule 3 and this Agreement.
- 9.5 The Parties agree that the Blockwiring Charges specified and adjusted in accordance with Schedule 3 shall apply for the term of this Agreement.

10. TERM REVIEW AND TERMINATION

- 10.1 This agreement commences on signing and shall continue until terminated in accordance with this clause 10.
- 10.2 This Agreement and all Contracts may be terminated by either Party giving 12 months notice to the other Party and such notice may be given at any time only after 4 years from the date of this Agreement.
- 10.3 Either Party may terminate this Agreement at any time with immediate effect by giving the other Party notice in writing if:
- (a) the other Party breaches a material provision of this Agreement (other than payment of Blockwiring Charges) and that breach is not remedied within 45 days after receiving written notice to do so;
 - (b) a Force Majeure event which substantially and adversely affects the ability of the other Party to perform its obligations under this Agreement continues for a period of at least 60 days;
 - (c) the other Party becomes subject to any form of insolvency administration or winding-up, unless there is a bona fide dispute between that Party and the person(s) seeking to subject that Party to insolvency administration or winding-up; or
 - (d) the Telecommunications Authority revokes the other Party's FTNS Licence.
- 10.4 Without prejudice to other parts of this Agreement, the Owner may terminate any Contract at any time with immediate effect by giving the Requesting Operator notice in writing if:
- (a) the other Party breaches a material provision of that Contract (other than payment of Blockwiring Charges) and that breach is not remedied within 45 days after receiving written notice to do so;
 - (b) the Requesting Operator breaches any payment provision of that Contract and that breach is not remedied within 30 days after receiving notice to do so in which case payment of the relevant sum and any overdue interest shall remedy the breach;
 - (c) a Force Majeure event which substantially and adversely affects the ability of the Requesting Operator to perform its obligations under that Contract continues for a period of at least 60 days; or
 - (d) an event described in clause 10.3(c) or (d) occurs.
- 10.5 The Owner shall be entitled to terminate any Contract at any time with immediate effect by giving appropriate notice to the Requesting Operator if arrangements have been made between the Owner, the Requesting Operator and a third party telecommunication service provider for the release of the relevant Blockwiring for use by that third party to serve a Subscriber who wishes to become the customer of that third party.
- 10.6 If a notice of termination of this Agreement (as opposed to an individual Contract) is issued in accordance with this clause 10, the Owner is not obliged to accept any new Orders from the Requesting Operator nor is the Owner obliged to fulfill any existing Orders from the Requesting Operator which have not been accepted pursuant to the provisions of Schedule 2.

- 10.7 A notice of termination of this Agreement shall be deemed to be a notice of termination of each Contract if the terminating event in respect of this Agreement also constitutes a terminating event for that Contract. This Agreement shall continue to apply to any Contract existing at the time of termination of the Agreement until termination of that Contract in accordance with this Agreement. Without prejudice to any other rights of the Owner to terminate each Contract in accordance with this Agreement, on giving notice to terminate this Agreement, the Owner may give notice to terminate a Contract with effect on the date which is the earlier of:
- (a) the expiration of the Minimum Contract Period; or
 - (b) the termination date of this Agreement.
- 10.8 Termination of this Agreement or any Contract shall not extinguish or otherwise affect any rights of any Party against the other which:
- (a) have accrued before the date of termination of this Agreement or that Contract; or
 - (b) otherwise relate to or may arise at any future time from any breach or non-observance of obligations under this Agreement or that Contract which arose before the date of termination of this Agreement or that Contract.
- 10.9 On termination of any Contract, the Requesting Operator must immediately pay to the Owner all Blockwiring Charges (whether or not due) which have accrued up to the date of termination and unpaid under that Contract.

11. USE OF BLOCKWIRING

- 11.1 The Requesting Operator must not use any Blockwiring provisioned to it under this Agreement or allow any other person to use that Blockwiring in such a way that may:
- (a) cause interference to the supply of telecommunications services supplied by the Owner or any third party to the relevant Blockwiring Building; or
 - (b) threaten the safety or well-being of any person or property in the relevant Blockwiring Building; or
 - (c) cause operational inconvenience to users of other wiring in the relevant Blockwiring Building.
- 11.2 If the Requesting Operator fails to remedy a breach of clause 11.1(a) or (c) within 3 Business Days of receiving written notice of such breach from the Owner, the Owner may suspend service of that Blockwiring. The Owner may terminate the Contract for that Blockwiring if the Requesting Operator does not within a further 7 Business Days rectify the breach to the reasonable satisfaction of the Owner.
- 11.3 If the Requesting Operator fails to remedy a breach of clause 11.1(b) immediately on receiving oral or written notice of such breach from the Owner, the Owner may suspend the use of that Blockwiring. The Owner may terminate the Contract for that Blockwiring if the Requesting Operator does not within 5 Business Days rectify the breach to the reasonable satisfaction of the Owner.
- 11.4 The Owner may not install a device to limit use of any Blockwiring provisioned to the Requesting Operator under this Agreement unless the Requesting Operator fails to

remedy a breach of clause 11.1(a) or (c) within 3 Business Days of receiving written notice of such breach from the Owner.

12. PROPERTY INTEREST

- 12.1 The Owner retains all right or title in the BIP (if it is provided by the Owner), the Blockwiring, the Local Box, and the Termination Socket and nothing in this Agreement or any Contract is to be construed as vesting such right or title in the Requesting Operator.
- 12.2 The Parties expressly acknowledge that the fact that _____ may use Blockwiring provisioned and maintained under this Agreement to comply with the Special Conditions of its FTNS Licence shall have no effect on the manner in which this Agreement is interpreted or on the extent of their respective obligations under this Agreement, nor shall this clause result in _____ to do an act on or before a particular date being less than it would have had this clause not been included in this Agreement.

13. FORCE MAJEURE

- 13.1 If a Party is unable to perform an obligation under a Contract or this Agreement (other than an obligation to pay Blockwiring Charges) by reason of a Force Majeure, that obligation is suspended to the extent that it is affected by, during the continuance of, the Force Majeure, if that Party:
- (a) gives the other Party prompt notice of the Force Majeure setting out the details of the Force Majeure and an estimate of the extent and duration of its inability to perform; and
 - (b) uses all possible diligence to remove that Force Majeure as quickly as possible.
- 13.2 If the Force Majeure continues for a period of 30 days after a notice given under this clause, without prejudice to each Party's rights under clause 10.3(b), the Parties must meet to discuss in good faith a mutually satisfactory resolution to the problem.
- 13.3 The requirement that a Force Majeure be removed with all possible diligence does not require the settlement of strikes, lockouts or other labour disputes or claims or demands by any government on terms contrary to the wishes of the Party affected.

14. CONFIDENTIALITY

- 14.1 The Parties acknowledge that the Confidentiality Agreement between them dated _____ applies to all confidential information disclosed by one Party to the other Party in relation to this Agreement.

15. LIMITATION OF LIABILITY AND INDEMNITY

15.1 Each Party acknowledges that this clause:

- (a) provides for certain exclusions and limitations by each Party of liability to the other Party for the other Party's Losses;
- (b) does not exclude or limit the application of any provision of the Applicable Law where to do so would:
 - (i) contravene that law; or
 - (ii) cause any part of this clause to be void; and
- (c) does not exclude or limit a Party's right to seek or obtain any remedy that may be available at law or in equity when damages are not an adequate remedy, including but not limited to an injunction or specific performance.

15.2 Notwithstanding clause 15.4 and 15.5 or any other provision of this Agreement, each Party excludes all liability to the other Party (whether under contract, tort, statute or otherwise) for any:

- (a) consequential or indirect Loss (including loss of revenue or profits) of the other Party;
- (b) liability of the other Party to any third party for any:
 - (i) consequential or indirect Loss (including loss of revenue or profits) of that third party (other than consequential or indirect Loss of a natural person for personal injury or death under a claim by a natural person referred to in clause 15.4(a) and 15.5(a)); and
 - (ii) direct Loss of that third party other than direct Loss of a type referred to in clause 15.4(a) or (b); and
- (c) liability of the other Party to any Government Agency under or in relation to the other Party's FTNS Licence (including under any performance bond relating to that Party's FTNS Licence),

suffered or incurred by the other Party during or after the term of this Agreement arising under or in any way out of or in connection with this Agreement or any Contract, the performance of this Agreement or any Contract or the termination of this Agreement or any Contract.

15.3 Other than Loss of a type referred to in clause 15.4, the liability of one Party to the other in contract, tort or otherwise (including any liability for negligence) arising by reason of or in connection with this Agreement and all Contracts is limited to \$1,000,000 for any one incident or series of events arising from a single incident or common cause and in no case shall a Party be liable for aggregate amount of in excess of \$5,000,000 for all liability arising by reason of or in connection with this Agreement and all Contracts.

15.4 Subject to clause 15.2, nothing in this Agreement or any Contract in any way excludes or restricts a Party's ("Indemnifying Party") liability to the other Party ("Innocent Party") for:

- (a) Losses of the Innocent Party for any claim against the Innocent Party by any natural person for any injury to or death of:
 - (i) any of the Indemnifying Party's personnel;
 - (ii) any of the Innocent Party's personnel; and
 - (iii) any other person,caused by negligence of the Indemnifying Party or its employees, agents or contractors arising out of or in connection with this Agreement or any Contract;
- (b) direct Losses for damage to or loss of any equipment, facility or other tangible property of the Innocent Party or any other person caused by the negligence of the Indemnifying Party or its employees, agents or contractors arising out of or in connection with this Agreement or any Contract; and
- (c) direct Losses arising from an intentional breach of this Agreement or any Contract by the Indemnifying Party or its employees, agents or contractors or any fraud.

15.5 Subject to clause 15.2, each Party ("Indemnifying Party") indemnifies the other Party ("Innocent Party") against all:

- (a) Losses of the Innocent Party for any claim against the Innocent Party in relation to any injury to or death of:
 - (i) any of the Indemnifying Party's personnel;
 - (ii) any of the Innocent Party's personnel; and
 - (iii) any other person,caused by negligence of the Indemnifying Party or its employees, agents or contractors arising out of or in connection with this Agreement or any Contract;
- (b) direct Losses arising from damage to or loss of any equipment, facility or other tangible property of the Innocent Party or any other person caused by the negligence of the Indemnifying Party or its employees, agents or contractors arising out of or in connection with this Agreement or any Contract; and
- (c) direct Losses arising from an intentional breach of this Agreement or any Contract by the Indemnifying Party or its employees, agents or contractors or any fraud.

15.6 Each Party:

- (a) excludes all conditions, warranties and representations implied by law or statute

except any implied condition, warranty or representation the exclusion of which would contravene the Applicable Law or cause this clause to be void (“Statutory Condition”); and

- (b) limits its liability for the breach of a Statutory Condition to the maximum extent permitted by law.
- 15.7 (a) The Requesting Operator shall ensure that the terms and conditions of service to the Subscriber shall include a provision that is designed, in so far as the Requesting Operator is legally able, to exclude the liability of any third party service provider to no lesser extent than the terms and conditions of service to the Subscriber exclude the Requesting Operator’s liability for Requesting Operator Subscriber Loss.
- (b) Notwithstanding clause 15.7(a), the Requesting Operator shall in any event ensure that the terms and conditions of service to the Subscriber shall include a provision that is designed, in so far as the Requesting Operator is legally able, to:
 - (i) exclude the liability of any third party service provider for all consequential and indirect Loss of the Requesting Operator Subscriber (including loss of revenue or profits); and
 - (ii) limit the liability of any third party service provider to direct proven Loss.
 - (c) Nothing in this clause requires the Requesting Operator to include any provision in the terms and conditions of service to the Subscriber that shall cause such exclusions and limitations of liability to be void at law.
 - (d) The Requesting Operator may provide a copy of the relevant provision containing the aforesaid exclusion and limitation of liability to the Owner for reference.
- 15.8 By virtue of and subject to this clause, the Requesting Operator confers on the Owner the benefit of the provision in the Subscriber Contract referred to in clause 15.7. The Requesting Operator must act as the Owner’s trustee and agent for the sole purpose of conferring the benefit of such a provision on the Owner as beneficiary and hold the benefit of that provision which is conferred on the Owner as a trustee for the Owner. The Requesting Operator shall not have any right to act on behalf of the Owner as agent, trustee or otherwise except as expressly set out in this clause.
- 15.9 The Requesting Operator indemnifies the Owner for any Loss suffered or incurred by the Owner as a result of a breach of clause 15.7 by the Requesting Operator.
- 15.10 The limitations of liability under this clause:
- (a) do not apply to any liability to pay Blockwiring Charges under this Agreement or any Contract; and
 - (b) are to be applied such that a Party’s limitations of liability under this Agreement or any contract are not exceeded as a result of any separate liability for the same event under any other agreement between the Parties.

15.11 This clause 15 survives termination of this Agreement or any Contract.

15.12 The exclusions and limitations of liability under this clause apply in aggregate for all Contracts and not as separate limitations or exclusions of liability under separate Contracts.

16. DISPUTE RESOLUTION

Working group

16.1 A Party may give written notice to the other setting out any dispute that Party has in relation to the subject matter of this Agreement whether or not this Agreement specifically calls for a dispute to be referred for resolution under this clause 16. On receipt of that notice each Party shall appoint representatives to a working group. The Parties shall ensure that their representatives use their best efforts to resolve the dispute.

Technical matters

16.2 Notwithstanding clause 16.1, the Parties shall refer disputes of a technical nature to a technical working committee established under the O & M Manual. The Parties shall procure that its representatives on the technical working committee use their best efforts to resolve the dispute in the manner set out in the O & M Manual.

Senior Management

16.3 If the working group or the technical working committee is not able to resolve the dispute within 14 days of that dispute being referred to it, the Parties shall refer to dispute to the senior management of both Parties for resolution who shall seek to resolve the dispute for further 14 days.

Settlement offers

16.4 Each Party acknowledges that any offer made by a representative of the other Party in an attempt to settle a dispute is made on a without prejudice basis unless specifically indicated otherwise in writing.

Without Prejudice

16.5 After complying with the procedure set out in this clause 16 a Party may approach the TA or exercise any legal right that may be available to it and this clause 16 is without prejudice to the right of a Party to seek the intervention of the TA or a court.

17. NOTICES

17.1 A notice, consent, request, order, application or any other communication ("communication") under this Agreement must be in writing and must be left at the address of the addressee, or sent by prepaid post (airmail if posted to or from a place

outside Hong Kong) to the address of the addressee or sent by facsimile to the facsimile number of the addressee specified below or any other address or facsimile number the addressee requests.

- 17.2 A written communication is deemed to be received:
- (a) if by hand delivery, when it is delivered;
 - (b) if a letter, three days after posting (seven, if posted to or from a place outside Hong Kong); and
 - (c) if a facsimile, at the time of dispatch if the sender receives a transmission report which confirms that the facsimile was sent in its entirety to the facsimile number of the recipient.
- 17.3 If a Party intends that communications on operational issues be sent to another addressee and facsimile number within its company, it may notify the other Party of the same by issuing a notice in the manner stated above in clause 17.1.
- 17.4 Communications received by a Party outside of normal working hours (being 9:00 am to

5:00 pm on any Business Day) shall be regarded as being received on the immediately following Business Day.

18. REGULATORY REVIEW AND MATERIAL LEGISLATIVE CHANGE

18.1 If any provision of this Agreement is in breach of any Applicable Law the Parties must negotiate in good faith such amendments to this Agreement that are necessary or appropriate to ensure consistency between this Agreement and the Applicable Law.

18.2 This Agreement (and all matters the subject of it) is conditional on all necessary governmental consents and approvals (including, without limitation, any necessary consents and approvals from the TA), if any, relating to or required for the offer, provision and use of Blockwiring, being obtained in terms reasonably satisfactory to both Parties as to form and content.

18.3 If any of the terms and conditions of this Agreement is subject to review by the TA and is not upheld in its entirety, the Parties shall negotiate in good faith to agree on a similar arrangement taking into consideration the outcome of the TA's review.

18.4 The provisions of this Agreement remain in full force and effect during any negotiations under this clause until the commencement of an Agreement replacing or amending this Agreement.

18.5 If the Parties are mutually unable to agree a solution within 3 months of commencing negotiations under this clause 18, either Party may terminate this Agreement with by giving 3 months advanced written notice to the other Party.

18.6 A Material Legislative Change occurs if:

- (a) the Telecommunication Ordinance is amended or repealed; or
- (b) a condition of a Party's FTNS Licence is amended or deleted or a new condition or rule is imposed; or
- (c) a lawful direction is made by the TA,

and such amendment, repeal, deletion, new condition or rule or direction materially effects the rights or obligations of either of the Parties under this Agreement.

18.7 If a Material Legislative Change occurs a Party may notify the other Party of that Material Legislative Change and the Parties shall then negotiate in good faith to agree such amendments to this Agreement as are necessary or appropriate to ensure consistency between this Agreement and the Ordinance, FTNS Licence or lawful direction.

18.8 Any present or future legislation which operates on a right, power or remedy of a person in connection with this Agreement is excluded except to the extent that:

- (a) its exclusion is prohibited or rendered ineffective by law; or

- (b) this Agreement specifically or by necessary implication provides to the contrary.

19. GENERAL

Acknowledgment

- 19.1 The Parties acknowledge that the existence of this Agreement or the inclusion of any specific right or obligation in this Agreement is entirely without prejudice to whether the grant of that right or the acceptance of that obligation falls within or outside the terms of section 36A of the Ordinance or any obligation under its FTNS Licence.

Cumulative rights

- 19.2 The rights, powers and remedies of a Party under this Agreement and any Contract are cumulative with the rights, powers or remedies provided by law independently of this Agreement or a Contract.

Exercise of rights and Good Faith

- 19.3 A Party may exercise a right, power or remedy at its discretion, and separately or concurrently with another right, power or remedy. A single or partial exercise of a right, power or remedy by a Party does not prevent a further exercise of that or of any other right, power or remedy.
- 19.4 Each Party shall act in good faith in seeking to agree any matters in relation to this Agreement and in the exercise of rights and the performance of obligations under this Agreement.

Waiver and variation

- 19.5 A provision or a right under this Agreement or any Contract may not be waived except in writing signed by the Party granting the waiver, or varied except in writing signed by the Parties.
- 19.6 Failure or delay of any Party at any time to take action against the other Party as provided in this Agreement or any Contract shall not affect such first-mentioned Party's right to require full performance of this Agreement or any Contract at any time thereafter. Waiver by any Party of a breach of any provision of this Agreement or any Contract shall not constitute a waiver of any subsequent breach nor in any way affect any right, power or remedy of that Party under this Agreement or any Contract.

Approvals and consents

- 19.7 A Party may give or withhold its approval or consent conditionally or unconditionally in its discretion unless this Agreement states otherwise.

Further assurances

- 19.8 Each Party must, at its own expense, do everything reasonably necessary to give full effect

to this Agreement and any Contract. Each Party must bear its own costs in negotiating, preparing and signing of this Agreement.

Amendments

19.9 This Agreement may not be amended except by written instrument executed by the Parties provided that, the Parties acknowledge that this Agreement may be amended at any time and from time to time in whole or in part in accordance with a determination lawfully made by the TA under Section 36A of the Telecommunications Ordinance.

Entire agreement

19.10 This Agreement contains the entire agreement and understanding between the Parties relating to Blockwiring and supersedes and cancels in all respects all previous letters of intent, agreements or arrangements between the Parties on this subject matter.

Relationship of the Parties

- 19.11 (a) The relationship between the Parties under this Agreement or any Contract is one of independent contractors only. Unless otherwise provided, nothing in this Agreement or any Contract is to be construed as creating an agency, partnership, association, trust or joint venture between the Parties.
- (b) Neither Party nor any of its employees, agents, representatives or contractors is to be deemed to be an employee, agent, contractor or representative of the other Party.
- (c) Other than expressly provided in this Agreement, neither Party has any authority to bind or oblige or incur any liability on behalf of the other Party and no such authority is to be implied.

Severability

19.12 If any provision of this Agreement or any Contract is construed to be illegal or invalid, it shall not affect the legality, validity and enforceability of the other provisions of this Agreement or that Contract. The illegal or invalid provisions shall be treated as being deleted from this Agreement or that Contract and no longer incorporated, but all other provisions of this Agreement and that Contract shall continue to be binding on the Parties.

Taxes

19.13 The Requesting Operator must pay all Taxes payable on this Agreement and any Contract, any sales, value added, consumption or similar Tax payable in relation to any goods and/or services provided under this Agreement or any contract and any Taxes payable in relation to this Agreement and the transactions evidenced by this Agreement that are introduced after the date of this Agreement (other than any income Tax payable by the Owner) except to the extent that such Tax is already reflected in a Charge variation pursuant to Schedule 3.

Assignment

19.14 Neither Party may assign any or all its rights, powers or remedies under this Agreement or any Contract without the prior written consent of the other Party, except that the Owner may assign ownership of any Blockwiring without the prior written consent of the Requesting Operator and either Party may assign any or all its rights, powers or remedies under this Agreement or any Contract to any of their Associated Companies capable of fulfilling the obligations under this Agreement and the relevant Contract without prior written consent of the other Party.

Governing Law and Jurisdiction

19.15 This Agreement is governed by the laws of Hong Kong.

19.16 Each party irrevocably and unconditionally submits to the non-exclusive jurisdiction of the courts of Hong Kong.

Counterparts

19.17 This Agreement may be executed in a number of counterparts. All counterparts together shall be taken to constitute one instrument.

Signed by

Signed by

SCHEDULE 1

PROVISIONING AND MAINTENANCE OF BIP

Terms defined in the Blockwiring Agreement apply in this Schedule.

Part A - Specifications

1. BIP Specifications

1.1 A typical module of BIP has a capacity for termination of 10 pairs of insulated copper wires on each side of the BIP module complying with the following specifications:

Connector Type : using Insulation Displacement Contacts (IDC) technique

Type of Contact : Normally closed with disconnection facility
(disconnection module)

Copper Wire Dimensions : 0.7 - 1.4 mm (including insulation) per slot to
accommodate two 0.4 - 0.65 mm copper cores per slot
or one 0.7 - 0.9 mm copper core per slot

Insulation Resistance : $\geq 5 \times 10^4$ M Ω

Dielectric Strength : ≥ 2000 V_{r.m.s.}

1.2 The Owner may from time to time inform the Requesting Operator by written notice of any change to the specifications set out in clause 1.1 of this Schedule, and BIP that are installed after the date of such notice shall comply with the new specifications.

2. A BIP that is provided by the Requesting Operator must comply with the BIP Specifications.

3. A BIP that is provided by the Owner must comply with the BIP Specifications and shall have a capacity that is capable of provisioning 50 pairs of Blockwiring circuit to the Requesting Operator. The Owner shall be responsible for increasing the capacity of the BIP to provision any Blockwiring in excess of 50 pairs which the Requesting Operator orders for in accordance with Schedule 2.

4. Each time when the Owner provisions Blockwiring requested in an Order, it shall connect a pair of jumper wires from the BIP or the termination point of a tie cable connecting to the BIP, to the Owner's MDF.

Part B - Application Procedures

5. BIP Application

5.1 Each BIP Application must be in writing and must state whether:

(a) the Requesting Operator is providing its own BIP, in which case the BIP Application must be in accordance with clause 5.2 of this Schedule and must state whether it is for new installation or expansion of installed capacity; or

(b) the Requesting Operator requests that the Owner provides the BIP, in which case the BIP Application must contain information specified in clause 5.3 of this

Schedule and must state whether it is for new installation or expansion of installed capacity.

5.2 Each BIP Application under clause 5.1(a) of this Schedule must contain the following information:

- (a) name of building;
- (b) location and diagram of the BIP;
- (c) proposed date on which the BIP is to be ready for the Requesting Operator to pre-wire its own tie cable to the BIP; and
- (d) contact person of the Requesting Operator; and

the Requesting Operator must ensure that the BIP is installed as close as practically possible to the Owner's MDF in the relevant Blockwiring Building.

5.3 Each BIP Application under clause 5.1(b) of this Schedule must contain the following information:

- (a) specified in clause 5.2 (a), 5.2 (c) and 5.2 (d) of this Schedule; and
- (b) desired quantity of circuit pairs to be terminated to BIP.

6. Response to Application

6.1 Within 7 Business Days of the receipt of a BIP Application, the Owner shall inform the Requesting Operator whether that BIP Application is accepted. The Owner may reject:

- (a) a BIP Application under clause 5.1(a) of this Schedule, if the proposed location of the BIP to be provided by the Requesting Operator is not suitable or is currently being used for another purpose, or the BIP Application does not contain information required by the Agreement and/or this Schedule; or
- (b) a BIP Application under clause 5.1(b) of this Schedule, if it is impractical for the Owner to accept the application due to constraints in respect of the Owner's in situ main distribution frame located in the MDF room of that building.

6.2 If the BIP Application for the Requesting Operator to provide its own BIP is not accepted because of the proposed location of the BIP, the Owner shall propose an alternative location and the Parties shall negotiate in good faith for an alternative location for the BIP.

6.3 If the Owner accepts a BIP Application for the Owner to provide the BIP, the Owner shall inform the Requesting Operator of the number and details of termination points available to the Requesting Operator for that BIP if specified capacity of BIP is allocated to the Requesting Operator in advance, the location of the BIP and the targeted date when the BIP shall be available for the Requesting Operator to run its own tie cable.

7. Provisioning Lead Time of BIP

7.1 Where the BIP is provided by the Owner, it shall use its reasonable endeavours to provision the BIP within 14 Business Days from the date it informs the Requesting Operator that the BIP Application is accepted.

7.2 The Parties acknowledge that the above provisioning lead time does not apply if:

- (a) the Owner receives a large number of requests to provision BIP within a short time frame, in which case the Requesting Operator shall be treated in a non-discriminatory manner;
- (b) permission of building management is required for installing the BIP and that permission is not obtained or is delayed;
- (c) the Blockwiring Building is on an outlying island, a restricted area or a hill top; or
- (d) customer's premises is not readily accessible.

7.3 If the BIP cannot be provided within the standard provisioning lead time, the Owner shall inform the Requesting Operator as soon as practical when the Owner becomes aware of it and shall propose an alternative available date.

8. BIP Expansion

8.1 If the BIP is provided by the Requesting Operator, the Requesting Operator is responsible for any necessary expansion of the capacity of the installed BIP. In the event that the Requesting Operator replaces an installed BIP or add an additional BIP and the location of the replaced or additional BIP is different from the location of the existing BIP, the Requesting Operator has to make a new BIP Application for the replaced or additional BIP under clause 5.1(a) of this Schedule.

8.2 If the BIP is provided by the Owner, the Requesting Operator shall keep track of the usage rate of the installed BIP. When the Requesting Operator reasonably foresees that the spare BIP capacity cannot meet the forecasted growth in the coming month, it shall make a new BIP Application to the Owner for additional BIP under clause 5.1(b) of this Schedule.

8.3 The Party who provisions the BIP shall be responsible for any cost to expand the capacity of that BIP.

9. BIP Replacement

9.1 This Schedule does not cover the situation of replacing a BIP which has already been installed and provisioned by the Owner other than for normal wear-and-tear of the BIP. The Parties shall negotiate in good faith in relation to such replacement.

- End of Schedule 1 -

SCHEDULE 2
SPECIFICATIONS, ORDERING, PROVISIONING AND
MAINTENANCE OF BLOCKWIRING

Terms defined in the Blockwiring Agreement apply in the Schedule unless the context requires otherwise.

Part A - Specifications

1. Blockwiring

The specifications for the Blockwiring are:

- (a) Physical Characteristics: two wire copper cable connection for voice grade application.
- (b) Bandwidth: 300 to 3400 Hz (measured at 3dB below maximum signal response).
- (c) Signal Attenuation: nominal 1.7 dB per km at 1600Hz.
- (d) Typical Loop Resistance: 300Ω maximum.
- (e) Insulation Resistance to Earth : 250KΩ minimum.
- (f) Circuit Random Noise: - 45 dBmp maximum.
- (g) DC continuity for supporting basic DC signaling required for operation of basic voice telephony.

Part B - Ordering Procedures for Blockwiring

2. Order

2.1 From time to time, the Requesting Operator may apply in writing for the provisioning of Blockwiring in a Blockwiring Building by the Owner. The request for a Blockwiring circuit shall constitute an individual Order, but the Requesting Operator may include several Orders in the same Order Form if all these Orders are in respect of the same customer, the same premises and the same Blockwiring Building and have the same proposed Available Dates.

2.2 Each Order in respect of a Blockwiring circuit should include:

- (a) the name of the Blockwiring Building;
- (b) whether Vertical Blockwiring or Vertical Blockwiring combined with Horizontal Blockwiring is required;
- (c) the floor for which a Vertical Blockwiring is required, and the floor and room/flat number if Horizontal Blockwiring is required;
- (d) diagrams showing location of BIP if it is provided by the Requesting Operator;

- (e) if only Vertical Blockwiring is required, whether the Requesting Operator shall provide a sub-local box and a location diagram of the sub-local box (if any);
- (f) the terminating point at the BIP
 - if it is provided by the Requesting Operator; or
 - if the BIP is provided by the Owner and specific capacity has been allocated to the Requesting Operator in accordance with Schedule 1;
- (g) the location of the Requesting Operator's sub local box if the Requesting Operator only requires Vertical Blockwiring from the Owner; or if the Requesting Operator provides Horizontal Blockwiring without sub local box, the location of the end of the Requesting Operator's Horizontal Blockwiring;
- (h) the proposed Available Dates; and
- (i) contact person of the Requesting Operator.

3. Response to Order

3.1 The Owner must respond in writing within 2 Business Days of receiving an Order Form containing not more than 2 Blockwiring and in any event within 5 Business Days of the date of receipt of any Order:

- (a) to accept that Order and, if the BIP is provided by the Owner but no capacity has been allocated to the Requesting Operator in advance under Schedule 1, the Owner shall specify the terminating point at the BIP for provisioning the Blockwiring requested under that accepted Order; or
- (b) to notify the Requesting Operator that the Owner's acceptance of the Order requires the resolution of a Review Event as set out in clause 3.2 below in which case clause 3.3 of this Schedule shall apply; or
- (c) to reject that Order because the requested Blockwiring is not available as set out in clauses 2.2(b) and 2.3 of the Agreement.

3.2 The Owner shall notify the Requesting Operator if any of the following matters affect an Order ("Review Event"):

- (a) the Order does not contain all the required information;
- (b) the period between the date of the Order is accepted and the proposed Available Date is less than the Standard Provisioning Period;
- (c) if retrofit work is necessary to provision Horizontal Blockwiring and/or Termination Socket;
- (d) arrangements for BIP in the relevant Blockwiring Building have not been made in accordance with the Agreement;
- (e) capacity of the existing BIP has to be expanded to provision the Blockwiring requested in the Order;
- (f) the Owner has received requests for a large number of Blockwiring to be provisioned within a short period of time;

- (g) if the Order Form contains several Orders and circumstances will require more than one site visit for provisioning Blockwiring under those Orders; or
 - (h) other circumstance which makes it difficult and/or impractical for the Owner to provision the requested Blockwiring in accordance with the terms and conditions of the Agreement.
- 3.3 If the Owner withholds acceptance of an Order or due to a Review Event, it shall notify the Requesting Operator as soon as practicable of the general nature of the relevant Review Event and the further time required to complete that review (which must be the least time that is practicable for the Owner to complete that review using its reasonable efforts).
- 3.4 If notice of a Review Event is given under clause 3.2(c), the Owner shall provide details of the work and costs involved to the Requesting Operator for its consideration. If notice of a Review Event is given under clause 3.2(e), the Owner shall propose an alternative arrangement for Requesting Operator to consider.
- 3.5 If notice of a Review Event is given under clause 3.2(f), the Owner shall propose alternative Available Dates for the Requesting Operator to consider and the Owner shall use its reasonable endeavours to procure those alternative Available Dates are as close as possible to the Available Date proposed by the Requesting Operator in the Order.
- 3.6 If notice of a Review Event is given under clause 3.2(g), the Owner shall propose the number of required site visits and the alternative Available Dates for the Requesting Operator to consider and the Owner shall use its reasonable endeavours to procure those alternative Available Dates are as close as possible to the Available Date proposed by the Requesting Operator in the Order. In calculating the number of required site visits, a single site visit requiring several persons shall be counted as multiple site visits.
- 3.7 If a notice of Review Event is given under clause 3.2(h), the Owner shall propose an alternative arrangement for the Requesting Operator to consider. Subject to an agreement between the Parties on the alternative arrangement, the Owner shall use its reasonable endeavours to procure that the alternative Available Date is as close as possible to the Available Date.
- 3.8 Upon receipt of proposal from the Owner under clauses 3.4, 3.5, 3.6 and/or 3.8, the Requesting Operator shall inform the Owner in writing whether the Owner's proposal is acceptable within 2 Business Days. If the Owner does not receive written confirmation or response from the Requesting Operator within this time period, the Requesting Operator is deemed to have cancelled the relevant Order.
- 3.9 If the Owner requires further information under clause 3.2(a), the Requesting Operator must provide the requested information within 2 Business Days. If the Owner does not receive the requested information within this time period, the Requesting Operator is deemed to have cancelled the relevant Order. After receiving the requested information, the Owner shall inform the Requesting Operator within 2 Business Days whether the Order is accepted in accordance with clause 3.1.
- 3.10 Acceptance of Order must be in writing and must specify the planned Available Date for each circuit ("Planned Available Date") which must not be earlier than the proposed Available Date stated in the Order. The Planned Available Date shall be the date calculated by adding the Standard Provisioning Period to the date of acceptance.
- 3.11 If the Requesting Operator requires Blockwiring to be provisioned earlier than the date they would otherwise be provisioned under this clause it shall notify the Owner that it requests earlier provisioning of the Blockwiring in which case:

- (a) the Owner shall notify the Requesting Operator of any overtime charges for provisioning the Blockwiring by that earlier date to be calculated according to the Owner's prevailing man-hour rates as described in the Charges Schedule; and
- (b) the Blockwiring shall be provisioned in accordance with the timetable agreed by the Parties.

The Owner shall endeavour to provision Blockwiring without incurring overtime charge, but if this will require commitment of resources by the Owner other than in accordance with its usual provisioning practices, the Owner shall inform the Requesting Operator of the additional charges for the Owner to meet the requirements. Any charges for labour incurred by the Owner under these circumstances shall be calculated in accordance with the Owner's prevailing man-hour rates as described in Schedule 3.

3.12 Normal Working Hours are from 9:00am to 5:00pm of a Business Day. Order must be received by the Owner and acceptance of Order must be received by the Requesting Operator during normal working hours. Order or acceptance of Order received after 5:00pm of a Business Day shall be regarded as received on the immediately following Business Day by the receiving Party.

4. Rejection of Order

4.1 The Owner may reject an Order if:

- (a) the Requesting Operator is in material breach of the Agreement; or
- (b) in the event that any of the Review Events apply and the Parties are not able to resolve that Review Event having negotiated in good faith in an effort to do so.

5. Variation or Cancellation

5.1 If the Requesting Operator wishes to vary or cancel, in whole or in part, an Order which has been accepted by the Owner, it must:

- (a) notify the Owner of that variation or cancellation in writing; and
- (b) pay the Owner the applicable variation or cancellation charge set out below:

<u>Variation / Cancellation</u>	<u>Variation / Cancellation Charges (% of Blockwiring One-off Charges)</u>
On the date of acceptance	nil
Between date of acceptance and 3 Business Days	
before the Planned Available Date	75%
Within 3 Business Days before the Planned Available Date	100%

For the purpose of calculating the variation or cancellation charge, the amount of Blockwiring One-off Charges that shall be included are the site-visit charge and the installation charge specified in Schedule 3.

5.2 Order variation is limited to variation of Planned Available Date only. If the Requesting Operator varies the Planned Available Date, the Parties shall negotiate in good faith to agree on a new Available Date. The Owner shall inform the Requesting Operator of any over-time work which is necessary for the Owner to agree to the newly proposed Available Date and the charges for such over-time work which shall be payable by the

Requesting Operator. For this purpose, the over-time work shall be charged at the Owner's prevailing man-hour rates as described in Schedule 3. If the Parties cannot agree on a new Available Date which is no later than 5 Business Days after the original Planned Available Date, the Order is deemed to be cancelled and the Requesting Operator must pay cancellation charge.

- 5.3 An Order for a specified Blockwiring circuit is deemed to be cancelled if the Requesting Operator informs the Owner that:
- (a) the Requesting Operator cancels the Order for that circuit;
 - (b) the Requesting Operator varies a matter specified in clause 2.2 (a) or (c) of this Schedule; or
 - (c) the Requesting Operator requests variation of other matter, and that variation shall require substantial change to the provisioning work already performed by the Owner, including arrangement or location of BIP or sub-local box (if any).

Part C - Standard Provisioning Period

6. Standard Provisioning Period

6.1 The Owner shall use its reasonable efforts to provision the Blockwiring requested in an Order within a period from the date of acceptance of that Order of:

- (a) 5 Business Days in the case of Blockwiring in Blockwiring Buildings for commercial use; or
- (b) 7 Business Days in the case of Blockwiring in Blockwiring Buildings for residential use.

6.2 The Owner shall use its reasonable endeavours to provision Blockwiring in accordance with the Agreement, but the Parties acknowledge that the following factors may affect the ability of the Owner to meet the above provisioning targets, and if any of the circumstances arises the Owner shall provide the Requesting Operator with an estimate of the provisioning period for that case:

- (a) a site visit is required;
- (b) line removal and line upgrade is required;
- (c) provisioning of a large number of Blockwiring is required within a short time frame, or the Owner has received a large number of requests from the Requesting Operator or other parties (in which case the Requesting Operator shall be treated in a non-discriminatory manner);
- (d) work by the Requesting Operator or Customer is required;
- (e) the Blockwiring Building is not readily accessible, or is located in outlying island, restricted areas or hill tops;
- (f) installation, expansion or replacement of BIP for the relevant Blockwiring Building is not yet completed; or
- (g) relocation of the Termination Socket.

- 6.3 If the event specified in clause 6.2 (c) of this Schedule, the Owner shall treat all the parties in a non-discriminatory manner and negotiate with the Requesting Operator in good faith for a plan to meet the Order.
- 6.4 If at any time after acceptance of an Order:
- (a) during its site visit to fulfill that Order, the Owner discovers that no suitable wiring is available; or
 - (b) the Owner has reason to believe that it shall not be reasonably practical in all relevant circumstances to provision the Blockwiring circuit by the Planned Available Date;

the Owner shall inform the Requesting Operator immediately and negotiate in good faith for an alternative solution or Available Date.

7. Notice of Available Date

- 7.1 When the Owner completes the provisioning of a requested Blockwiring, it shall issue a completion notice to inform the Requesting Operator of the Available Date of that Blockwiring.

Part D - Maintenance

8. Target Restoration Time

- 8.1 If the Owner receives a fault notification during its normal working hours which is given by the Requesting Operator in accordance with the Agreement, the Owner shall use its reasonable endeavours to restore service of the faulty Blockwiring on or before the end of next day after receipt of fault notification by the Owner. If the Owner offers a shorter standard target restoration period to its other customers in similar circumstances from time to time compared to the target restoration period specified in Schedule 2, the Owner shall negotiate in good faith to consider revisions to the target restoration period specified in Schedule 2.
- 8.2 The Parties acknowledge that the following factors may affect the ability of the Owner to meet the above maintenance targets:
- (a) the Subscriber's premises are inaccessible or the need to coordinate an appointment where work on the Horizontal Blockwiring and/or the Termination Socket is required;
 - (b) power failure at the relevant Blockwiring Building;
 - (c) additional time awaiting approval from the Requesting Operator, management of the relevant Blockwiring Building, and/or the Subscriber;
 - (d) natural disaster;
 - (e) major cable fault;
 - (f) weather constraints, such as thunderstorm, black rain storm or typhoon warnings or any other weather condition which may affect staff safety on carrying out repair duties;
 - (g) public transportation is not available;

- (h) the Blockwiring Building is not readily accessible, or is located in outlying island, restricted areas or hill tops; or
- (i) replacement / removal of wiring is required.

9. Maintenance Responsibilities

9.1 The Requesting Operator shall be responsible for the maintenance of those facilities which it provides in respect of a specified Blockwiring, including:

- (a) the BIP;
- (b) the tie cables connecting the BIP with the termination point of the Owner's main distribution frame if the BIP and the Owner's main distribution frame are located in different rooms, or if the cable distance of a tie cable is more than 10 meters;
- (c) the sub-local box;
- (d) the horizontal wiring; and
- (e) the customer termination socket that the Requesting Operator provides.

9.2 The Owner shall be responsible for the maintenance of those facilities it provides in respect of a specified Blockwiring including:

- (a) the Owner's BIP, or alternatively the jumpers for connecting the Requesting Operator's BIP to the Owner's MDF if the cable distance between the Requesting Operator's BIP and the Owner's MDF is 10 meters or less and the Owner's main distribution frame is located in the same room;
- (b) the Vertical Blockwiring and the Local Box if only Vertical Blockwiring is being provisioned by the Owner;
- (c) the Vertical Blockwiring and Horizontal Blockwiring if both are being provisioned by the Owner;
- (d) the short run of jumpers for connecting the Local Box and the Requesting Operator's sub-local box, or alternatively the B-wire connector and the jumper for connecting the Local Box and the B-wire connector, as may be applicable.

9.3 Termination Socket shall be provided by Owner except in the instances referred to in clause 9.2(d) of this Schedule.

9.4 While performing maintenance work, the Requesting Operator must not interfere with the wiring circuits and other facilities of the Owner, except:

- (a) the demarcation point at the BIP;
- (b) the demarcation point at Requesting Operator' sub local box;
- (c) the B-Wire connector end of the horizontal blockwiring provided by the Requesting Operator; and
- (d) the Termination Socket provided that the work is subject to and in accordance with the terms and conditions of the Agreement.

10. Fault Handling and Reporting

- 10.1 Each Blockwiring shall be given a circuit identity in the notice of Available Date given by the Owner in accordance with this Schedule, and this identity is used for reference in all communications between the parties.
- 10.2 The Parties shall operate a fault reporting point to deal with faults or service problems relating to Blockwiring. The Requesting Operator shall receive and handle fault reports from its customer and shall perform the necessary fault investigation. If the faults are identified as located in Owner's Blockwiring section, the Requesting Operator should report them to the Owner together with the necessary information and identification.
- 10.3 If the maintenance work to be performed by the Owner involves replacement of any circuit or any planned outage, the Owner must use its reasonable endeavours to minimise any service interruption to Subscribers of the Requesting Operator because of such replacement and must:
- (a) in the case of replacement of all of the Blockwiring in a building for preventative maintenance purposes - give at least 1 month prior notice to the Requesting Operator; or
 - (b) in the case of other replacements - give the Requesting Operator notice where the Owner would give its customers in similar circumstances notice of such replacement, except where such notice is not practical due to emergency.

Part E - Relocation

11. Relocation of Subscriber

- 11.1 If a Subscriber to whom the Requesting Operator is providing service over a Blockwiring wishes to relocate to another premises within the same Blockwiring Building, the Requesting Operator may place a relocation order with the Owner which must contain the following information:
- (a) the address of the original premises;
 - (b) all the relevant information required for an Order; and
 - (c) confirmation that the user of services provided over the Blockwiring before relocation and after relocation is the same party.
- 11.2 The provisions of the Agreement and this Schedule in relation to Orders shall apply to the orders for relocation under this clause.
- 11.3 The Requesting Operator agrees to pay the relocation charge specified in Schedule 3, which charge shall include relocation of the Vertical Blockwiring and/or Horizontal Blockwiring within the same Blockwiring Building.
- 11.4 Relocation described in this clause 11 shall be deemed as a termination of the Contract in respect of the original Subscriber premises. If termination of the subject Contract occurs within the Minimum Contract Period, the Requesting Operator shall not have to pay Blockwiring Recurrent Charges referred to in Schedule 3 for the remaining Minimum Contract Period of that Contract if the user of telecommunication services provided over the Blockwiring at the new Subscriber premises is the same user as the original Subscriber premises.

- 11.5 The Blockwiring after relocation shall be subject to a new Contract with a Minimum Contract Period which commences on the Available Date when the relocation is completed.
- 11.6 This clause 11 does not cover relocation of Termination Socket within the same Subscriber premises.

- End of Schedule 2 -

SCHEDULE 3
CHARGES SCHEDULE

Terms defined in the Blockwiring Agreement apply in the Schedule.

Blockwiring Charges

1. BIP Charge

1.1 The BIP Charge is HK\$4,758, and is one-off charge payable by the Requesting Operator on every occasion where the BIP is provisioned by the Owner.

2. Blockwiring One-off Charges

2.1 Blockwiring One-off Charges in respect of each Blockwiring consists of:

- (a) site-visit charge of HK\$223 for each visit made by the Owner for provisioning;
- (b) an installation charge of HK\$22 for each Vertical Blockwiring (if only Vertical Blockwiring is requested); and
- (c) an installation charge of HK\$111 for each Vertical Blockwiring combined with Horizontal Blockwiring.

2.2 In respect of Orders that are contained in one Order Form duly issued in accordance with Schedule 2 and which are in respect of provisioning Blockwiring to the same Subscriber at the same premises with the same Available Date, the Owner may be able to complete several Orders during the same site-visit. In these circumstances where no separate visit is required for provisioning each Order, the site-visit charge specified in clause 2.1(a) of this Schedule is payable for only the actual visits made.

3. Blockwiring Recurrent Charge

3.1 HK\$7.62 per month in respect of each Vertical Blockwiring; or

3.2 HK\$12.50 per month in respect of each combined Vertical Blockwiring and Horizontal Blockwiring.

4. Relocation Charge

HK\$334 for each relocation as described in Schedule 2.

Adjustments of Blockwiring Charges

5. During the term of the Agreement, each of the above Blockwiring Charges set out in clauses 1 to 4 (inclusive) of this Schedule shall be subject to an annual increase on and from each Review Date until the next Review Date based on the formula described below:

$$A = B \times C/D.$$

6. For the purpose of the above clauses, the following shall apply:

A is the adjusted amount which applies on and from the Review Date;

B is the amount of the relevant charge as at the Base Date;

C is the CPI (A) index for Hong Kong last published before the Review Date;

D is the CPI (A) index for Hong Kong last published before the Base Date;

The Base Date is 1st July 1999 and for each subsequent review after the first review, is the anniversary of that date immediately prior to that Review Date; and

The Review Date is 1st July of each year.

If the CPI (A) for Hong Kong ceases to be published quarterly, then for the purposes of applying this clause, the CPI(A) for Hong Kong is to be replaced by the nearest equivalent index published at that time. The average figure of the CPI(A) over the relevant 12 month period shall be used for the purpose of this clause.

If any adjustments are made in accordance with this clause, and the adjustment commences on a date other than the first day of a calendar month, the charges due for that month should be the pro-rata calculated on a 30-day month basis.

No adjustment shall be made under clauses 5 of this Schedule if the resulted Blockwiring Charges after making an adjustment would be lower than the amount payable without making that adjustment.

7. Man-Hour Rate

7.1 The prevailing man-hour rate referred to in this Schedule 3 and in Schedule 2 is the Owner's prevailing man-hour rate at the material time. The Owner shall notify the Requesting Operator of the prevailing man-hour rate from time to time and on request by the Requesting Operator.

7.2 In respect of each occasion of visit or work for which the Requesting Operator has to pay the Owner based on the prevailing man-hour rate under the Agreement or any of the Schedules, this clause applies. As of the date of the Agreement, prevailing man-hour rates are as follows:

(a) for work performed during normal working hours HK\$314.

(b) for work performed outside normal working hours HK\$397.

For the purpose of this Schedule, man-hour rates shall equivalent to relevant man-hour rates.

In respect of each occasion of visit or work performed by the Owner under paragraph (b), the Requesting Operator must pay for a minimum of 2 man-hours and any travelling expenses incurred to attend or perform work during the hours specified in that paragraph.

8. Billing

8.1 The Owner shall issue and send invoices to the Requesting Operator on a monthly basis in accordance with the terms set out in this Schedule. Each invoice should include the following details:

- (a) invoice issue date;
- (b) invoice due date;
- (c) any brought forward amount of previous invoices;
- (d) amount payable for each category of Charges and (where applicable) a breakdown of the number of man-hours included in the calculation in respect of the month covered by invoice;
- (e) interests on any overdue amounts;
- (f) total amount payable;
- (g) the amount of any credit arising from any disputed amount which was paid.

8.2 The following billing principles are applicable to this Schedule:

- (a) Charges that are recurrent shall be payable one month in advance and shall be billed on a monthly basis;
- (b) An invoice for all Charges (other than Charges that are recurrent) payable in respect of any calendar month shall be issued at the beginning of the immediately following month;
- (c) the Owner shall issue a consolidated invoice for all Charges payable in respect of a specified month and shall provide a breakdown on a per exchange basis as soon as such alternative is available within the Owner's system; and
- (d) Invoices shall be issued on or before the 10th calendar day of each calendar month.

9. Payment

9.1 All invoices must be settled in Hong Kong dollars by company cheques made payable to the Owner or by electronic transfer to the nominated bank account of the Owner. Payment must be credited to the Owner on or before the invoice due date.

9.2 Invoiced amounts, other than overdue interests, are due in full within 30 calendar days from the date of issue of the invoice or next working day if it is a holiday. Each invoice issue date should not be earlier than the dispatch date of that invoice. Overdue interests are due immediately.

9.3 If an invoice is not paid by the invoice due date, the Requesting Operator must pay interest in respect of the overdue amount. Overdue interest shall be calculated at the rate (the "Interest Rate") which is equal to 2% above the prime lending rate of The Hongkong and Shanghai Banking Corporation Limited as current from time to time. Interest shall accrue daily on all outstanding amounts (including accrued overdue interest) from the due date until payment in full is received by the Owner. Interest shall continue to accrue despite termination of the Agreement.

9.4 If the Requesting Operator pays an amount which is subsequently resolved under clause 10 of this Schedule not to have been due, the Owner shall credit the Requesting Operator for that amount plus interest calculated in accordance with clause 9.3 of this Schedule from the date of actual payment to the date of the credit in the next invoice following that resolution.

10. Dispute Resolution

10.1 If the Requesting Operator bona fide disputes the whole or part of an invoice, the Requesting Operator must pay that portion of the invoiced amount which is not disputed. Overdue interest shall accrue in respect of the non-disputed portion if it is not paid by the invoice due date. The disputed portion is not payable by the Requesting Operator until the dispute is resolved (provided that the Requesting Operator complies with the terms set out in this section) and provided the resolution of the dispute determines that the Requesting Operator should pay the disputed amount. Without prejudice to the Agreement and for the avoidance of doubt, any matter relating to service levels and specifications does not constitute a subject matter for dispute under this clause 10.

10.2 If the Requesting Operator disputes an invoice, the Requesting Operator must notify the Owner in writing specifying:

- (a) the invoice in dispute;
- (b) the amount in dispute;
- (c) reasons for dispute; and
- (d) supporting documentation as appropriate.

10.3 Notification of dispute must be delivered by hand or by post or by facsimile and must reach the Owner within 25 calendar days from the date of receipt of the invoice by the Requesting Operator. Any dispute raised after 25 calendar days from date of receipt of the invoice by the Requesting Operator shall not be considered, and the invoice must be settled in full by the invoice due date.

10.4 Dispute Investigation

- (a) In respect of any dispute, the Parties shall investigate any discrepancy that may have occurred in relation to the disputed items. Alternatively, the Parties shall arrange for joint investigation whether there is substantial discrepancy between the records maintained by the Parties. Such joint investigation is expected to be completed within 14 Business Days from the dispute notification date.
- (b) A dispute is not valid if there is no substantial error found in respect of the invoice in dispute within 14 Business Days from the dispute notification date. If the dispute is not valid, the Requesting Operator must pay overdue interest on the disputed amount commencing from the original invoice due date.

10.5 Non-settlement of Dispute

The Parties must use their reasonable efforts to promptly resolve any dispute notified under this section. If the Parties are unable to resolve any dispute in relation to the accounting process which affects the amount in dispute within 14 calendar days after notification of the dispute, each Party shall refer the dispute to its senior management for resolution by any means it deems suitable which may include referring the matter to a certified chartered accountant to act as an expert or taking legal action.

10.6 Resolution

- (a) Following the dispute investigation, the Requesting Operator must pay the amount resolved under clause 10.3 or 10.4 of this Schedule to be payable (“resolution amount”) and overdue interest on the resolution amount to be calculated from the original invoice date to the actual payment date.
 - (b) Any resolution amount (including principle and interest) must be settled within 7 Business Days of the dispute resolution date.
- 10.7 If the Owner does not receive the outstanding principle and interest within 7 Business Days from the dispute resolution day, it may include overdue interest in respect of these amounts in the next invoice issued to the Requesting Operator.

- End of Schedule 3 -

**DRAFT SECTIONS TO BE INCLUDED IN THE O&M MANUAL FOR
BLOCKWIRING AGREEMENT**

Terms defined in the Blockwiring Agreement apply in this O& M Manual.

1. Specifications of B-Wire Connector

A typical B-Wire connector is capable of jointing any 2 insulated copper wires of any combination between 0.4 mm and 0.9 mm in diameter, without stripping off the insulation.

2. Provisioning of Blockwiring

2.1. Provisioning at BIP

2.1.1. BIP provided by the Requesting Operator

- ◇ the Requesting Operator to identify the BIP termination point when placing Order
- ◇ the Owner to run a jumper connecting the Blockwiring circuit and the corresponding termination point at BIP or at termination point of a tie cable connecting to a BIP

2.1.2. BIP provided by the Owner and solely used by the Requesting Operator

- ◇ the Requesting Operator to identify the BIP termination point when placing Order
- ◇ the Owner to connect the Blockwiring circuit to the corresponding termination point at BIP or at termination point of a tie cable connecting to a BIP

2.1.3. BIP provided by the Owner but not solely used by the Requesting Operator

- ◇ the Owner to identify the BIP termination point when confirming Order
- ◇ the Requesting Operator to connect the cable pairs from its network to the termination point at BIP

2.2. Provisioning at sub-local box

If the horizontal section is provided by the Requesting Operator and

a) the Requesting Operator has sub-local box:

- ◇ the sub local box should be as close as practically possible to the Owner's Local Box

- ◇ the Owner to extend a short run of jumper wires from its Local Box, with suitable identification, and the Requesting Operator to connect the jumper wires to the Requesting Operator sub-local box
- b) the Requesting Operator has no sub-local box:
 - ◇ the Requesting Operator to extend the horizontal section, with suitable identification, for joining to the Owner's Local Box
 - ◇ the Owner to connect the Requesting Operator's horizontal section to the Vertical Blockwiring using B-wire connector
 - ◇ the Requesting Operator is recommended to provide suitable protection to the horizontal section, including the B-wire connector

2.3 Termination Socket

- ◇ In case the Horizontal Blockwiring is provided by the Owner, the provision shall also include its standard Termination Socket if it has been provisioned and is in-situ.
- ◇ The Requesting Operator may apply a branded removable adhesive sticker to the Termination Socket or replace the Termination Socket with the Requesting Operator's own socket. However, the Requesting Operator has to reinstate the Termination Socket to the condition when the Horizontal Blockwiring section was provisioned on the RFU date.
- ◇ If the Requesting Operator decides to replace the Termination Socket with the Requesting Operator's own socket, the Requesting Operator has to inform the Owner.

3. Provisioning of Blockwiring Interface Point

If the BIP is provided by the Requesting Operator, the BIP must be as close as practically possible to the Owner's MDF in the building MDF room. The Requesting Operator can either:

- a. connect cable(s) from its equipment to the BIP termination points given by the Owner when the Requesting Operator places Order for the Blockwiring; or
- b. prewire cables from its equipment to the BIP termination points allocated to the Requesting Operator giving the Owner 5 Business Days prior notice. The Requesting Operator has to inform the Owner the termination point for each Blockwiring circuit when placing Orders to the Owner.

4. Identification of BIP and Blockwiring Circuits

4.1 Identification of BIP

The BIP provider, either the Owner or the Requesting Operator, shall provide proper visual identification to the BIP. The parties shall agree to the following naming identification.

4.2 Identification of Blockwiring Circuit

<To be agreed>

5. Maintenance Procedures

5.1 Maintenance of BIP

The party providing the BIP is responsible for its maintenance.

5.2 Fault Reporting Procedures

Both the Requesting Operator and the Owner shall operate a fault reporting point to deal with faults or service problems relating to Blockwiring. The Requesting Operator shall receive and handle all fault reports from its customer and shall perform the necessary fault localization. If faults are found residing in the Owner's Blockwiring section, the Requesting Operator shall notify the Owner via the nominated fault reporting point, giving the following details.

- ◆ circuit identity
- ◆ address information
- ◆ fault symptoms
- ◆ time of occurrence
- ◆ suspected faulty section
- ◆ any other information which the Requesting Operator considered useful to the Owner for rectifying the faults

The Owner and the Requesting Operator shall exchange a unique fault reference number for each fault reported and that number shall be used at all times when referring to that particular fault case.

5.3 Fault Handling

During the fault investigation period by the Owner, the Owner may need to disconnect the Blockwiring circuits at the BIP or at the sub local box. The Owner may also require assistance from the Requesting Operator in testing the faulty circuits.

There may also be cases where the Owner's staff shall have to enter the customer premises to perform the fault investigation or restoration and if this

is the case, the Owner shall notify the Requesting Operator to arrange a joint visit.

Upon clearing the fault, the Owner shall provide the Requesting Operator the fault restoration time and action taken to restore the fault. The fault docket is then closed. The Owner shall work towards the agreed target restoration time specified in Schedule 2 of the Blockwiring Agreement. The performance shall be reviewed in the Service Review meeting in accordance with paragraph 10 below.

5.4 Replacement of Blockwiring

If the Requesting Operator notifies the Owner of a fault in the Blockwiring leased to the Requesting Operator and the Owner confirms that replacement of the Blockwiring is required, the Owner shall inform the Requesting Operator before replacing that Blockwiring.

Whenever a replacement of a cable is required and some Blockwiring circuits of that cable have been leased to the Requesting Operator, the Owner shall give 7 Business Days prior notice to the Requesting Operator for such replacement together with an estimation of time required for the replacement.

6. Suspension and Resumption of Blockwiring Services

6.1 Suspension of Blockwiring Services

If the Requesting Operator is in breach of clause 11.1 of the Agreement, the Owner may suspend service of a Blockwiring in accordance with clauses 11.2 and 11.3 of the Agreement, as applicable.

The Owner shall provide reasons for the suspension in the suspension notice.

6.2 Investigation before Suspension

The parties shall commence negotiations in good faith within 1 Business Day after the Requesting Operator has received the suspension notice under clause 11.2 of the Agreement. The parties shall investigate the reasons of the breach of clause 11.1 of the Agreement by the Requesting Operator and shall cooperate to resolve the matter in a mutually acceptable manner. If the parties reach an agreement before the suspension date, the breach is regarded as remedied and the Owner shall not suspend the Blockwiring service.

6.3 Resumption of Service after Suspension

The Owner shall resume the Blockwiring service to the Requesting Operator if the Requesting Operator provides confirmation to the Owner that the reasons for suspension had been removed within a period of 4 Business Days after the suspension.

7. Procedures for Disconnection / Reconnection of Termination Socket

The first termination point at customer premises for a typical Horizontal Blockwiring circuit provided by the Owner is a standard master-line modular socket. The circuit may be further extended within the same premises and reterminated to a number of secondary-line sockets for parallel line operation.

If the Requesting Operator has replaced the Owner's sockets, the Requesting Operator has to reinstate the Termination Sockets to the condition when the Horizontal Blockwiring was provisioned on the RFU date. The following diagram shows the wiring of the master line and secondary line modular sockets.

8. Safety

Each party shall notify the other party of any Blockwiring that is unsafe for the person working in the vicinity of that Blockwiring.

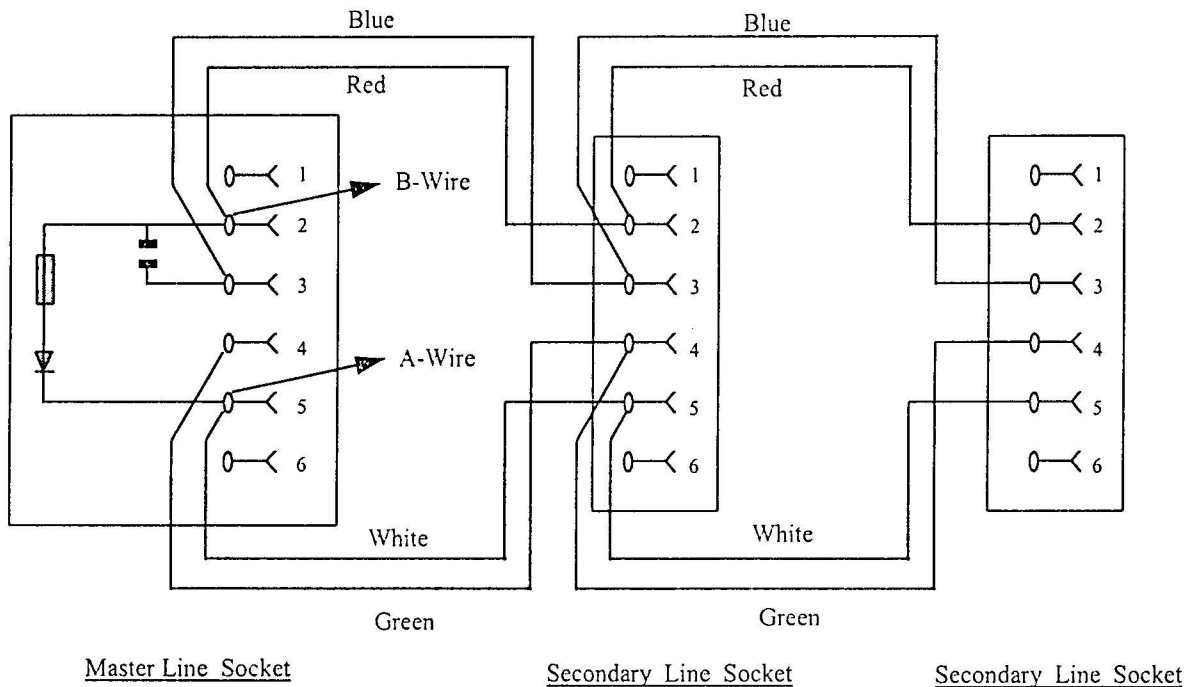

Notes :

1. The capacitor will be connected in series with the ringing detection circuit of the telephone.
2. The secondary line socket is identical to the master line socket except without electronic components.
3. Terminals 2 & 5 are connected to the exchange line.

Configuration Diagram - Blockwiring Provision

Scenario 1

only vertical blockwiring circuit is included

Scenario 2

both horizontal and vertical blockwiring circuits are included

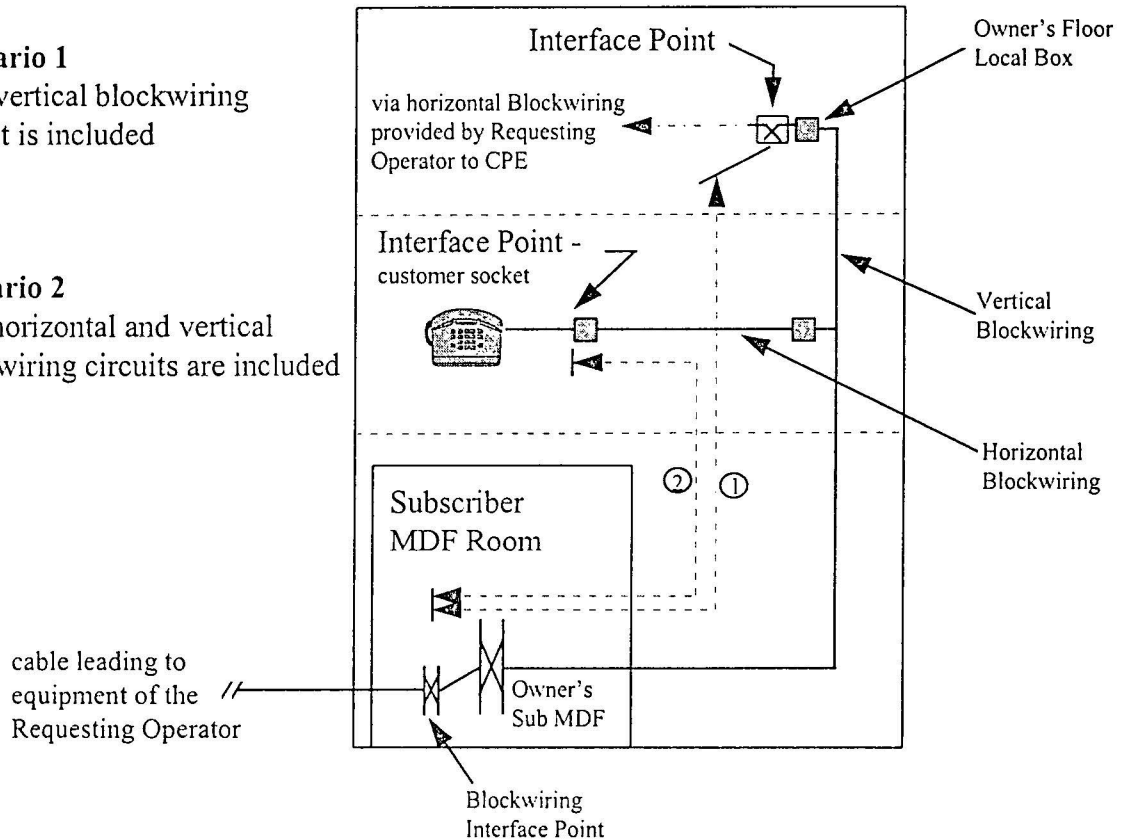

9. Procedures for Relocation

(to be discussed by the Parties)

10. Service Review

The Owner and the Requesting Operator shall finalise the draft version of this O&M Manual within 1 month of the date of signing the Agreement. The procedures stated in the Manual shall be adopted for provisioning and maintenance of Blockwiring services. After both parties have gained hand-on experience on the procedures, the procedures and service lead time shall be reviewed.

The Owner and the Requesting Operator shall review the overall provisioning and maintenance procedures and service standard in service review meetings. The service review meetings shall be held monthly but the frequency shall be subsequently reviewed. In the service review meetings, problems and difficulties encountered and possibilities for further improvements, both to the operational procedures and service levels, shall be reviewed.